

# Diamond Turning Tools

## Synthetic Diamond

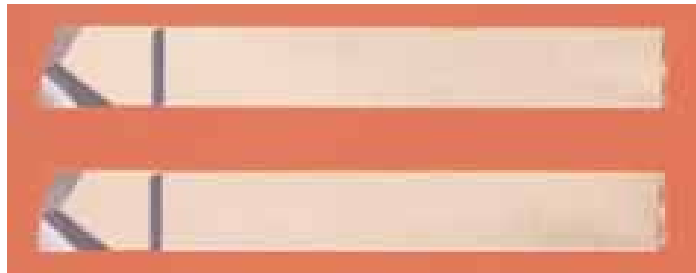

Diamond tipped turning tools shown are used in the finishing of the commutator surface. Steep rake angles on the tool ensure clean cutting of the copper, leaving no smearing or drag over across the mica. The nose radius of .010" leaves a very smooth surface to the copper requiring minimal preparation for the seating of brushes.

Right-hand tools cut right to left, left-hand tools cut left to right, with tool positioned diamond side up, as used in most commutator turning applications.

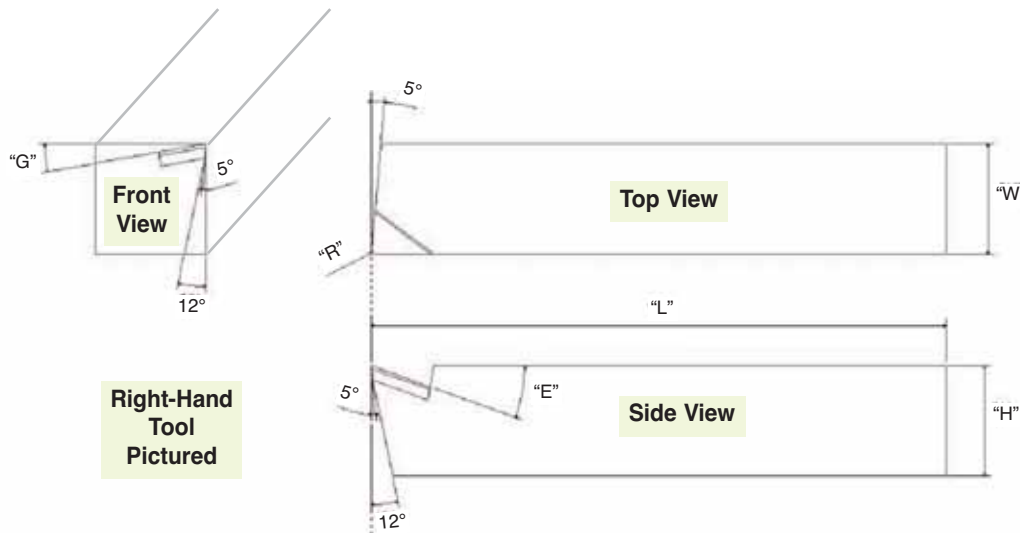

W	H	L	G	E	R	Left Hand Catalog Number	Right Hand Catalog Number
3/8"	3/8"	3"	10°	20°	.010"	DIAWTT38L	DIAWTT38R
1/2"	1/2"	3-1/2"	10°	20°	.010"	DIAWTT12L	DIAWTT12R
5/8"	5/8"	4"	10°	20°	.010"	DIAWTT58L	DIAWTT58R
3/4"	3/4"	5"	10°	20°	.010"	DIAWTT34L	DIAWTT34R
1"	1"	6"	10°	20°	.010"	DIAWTT1L	DIAWTT1R
10mm	10mm	75mm	10°	20°	.25mm	DIAWTT10MML	DIAWTT10MMR
12mm	12mm	87.5mm	10°	20°	.25mm	DIAWTT12MML	DIAWTT12MMR
20mm	20mm	125mm	10°	20°	.25mm	DIAWTT20MML	DIAWTT20MMR
25mm	25mm	150mm	10°	20°	.25mm	DIAWTT25MML	DIAWTT25MMR

