

Folds linings up to 8" wide, any length.

Model RC will handle insulation material up to 8" wide between its guides. Creasing rollers are adjustable sideways to make troughs up to 6" wide. A fixed ruler-guide makes it easy to accurately set these widths.

Vertical adjustments of the roller shaft allow for different thicknesses of insulation material and for varying pressures between creasing rollers and rubber roller.

	Catalog Number
Model RC Insulation Folder . . . . .	.INFLRC
Net Weight 22 lbs., Shipping Weight 24 lbs.	
Replacement Rubber Roller . . . . .	.INFLK324
Replacement Creasing Roller (two required) . . . . .	.INFL1176

## Model No. 40 Armature Winder

Model 40 Armature Winder is a convenient, manually operated unit that winds straight or skewed armatures. Typical applications include fans, grinders, fractional H.P. motors, automotive starters and generator armatures. Handles up to 6" diameter and 8" core length armatures.



	Catalog Number
Model 40 Armature Winder . . . . .	.CWDE40
Net Weight 9 lbs., Shipping Weight 13 lbs.	



# Coil Winding Equipment

Three Systems: Light Duty, Medium Duty, and Heavy Duty

## Light Duty Coil Winding

**No. 41 Wire Rack** offers a convenient means of storing wire, plus an efficient system for feeding wire up to size 14. Prevents tangled or broken wire and damaged insulation caused by rotating inertia of reels; No. 41 capacity is 24 buckets or reels.

The 24" frame extension on the front of the rack can be used for mounting a tension device. See tension device below.

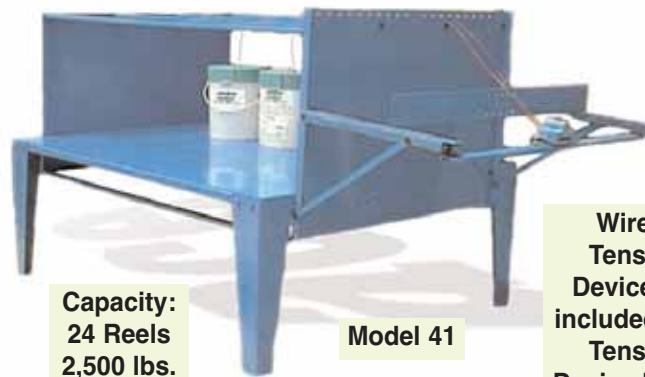

**Capacity:**  
24 Reels  
2,500 lbs.

Model 41

Wire & Tension Device not included. See Tension Device below.

Model	Shipping Weight	Catalog Number
41	350 lbs.	CWDE41

**4901 Capstan Tension Device** is a rotary tension unit, which provides well regulated and easily adjusted wire tension. One of these devices is positioned over each spool of wire to be used. This device consists of a steel frame which supports the tension assembly of a spindle, 3" dia. pulley, brake hub, brake disk, brake spring and tension adjusting nut. Ceramic bushings in the spindle at the bottom guide the wire coming upward from the spool. A spring loaded clamp with a felt lining holds the wire on the pulley and also removes some of the oil from the wire.



Model	Shipping Weight	Catalog Number
4901	7 lbs.	CWDE4901

### Model 75 & 76 Variable Speed Coil Winders:

Automatic stop with infinitely variable speed range. Constant torque with soft start and controlled acceleration by the foot pedal. A permanent magnet DC motor drives a helical gear reducer. 8" Dia. face plate with 4 slots to fasten your fixtures. Winding Speeds: 0 to 390 r.p.m.



Model	H.P.	Torque	Voltage	Shipping Weight	Catalog Number
75	1	13 lb. Ft.	120 V.	300 lbs.	CWDE75
76	2	26 lb. Ft.	240 V.	350 lbs.	CWDE76



**MARTINDALE** • 1375 Hird Ave • Cleveland, OH 44107  
 Phone (216) 521-8567 • Fax Local 521-9476 / USA & Canada (800) 344-9191  
 E-Mail: sales@martindaleco.com  
 Web Site: [www.martindaleco.com](http://www.martindaleco.com)

**Medium Duty Coil Winding**

**No. 42 Wire Rack** offers a convenient means of storing wire, plus an efficient system for feeding wire up to size 14. Prevents tangled or broken wire and damaged insulation caused by rotating inertia of reels; No. 42 capacity is 40 buckets or reels.

The 24" frame extension on the front of the rack can be used for mounting a tension device. See tension device below.

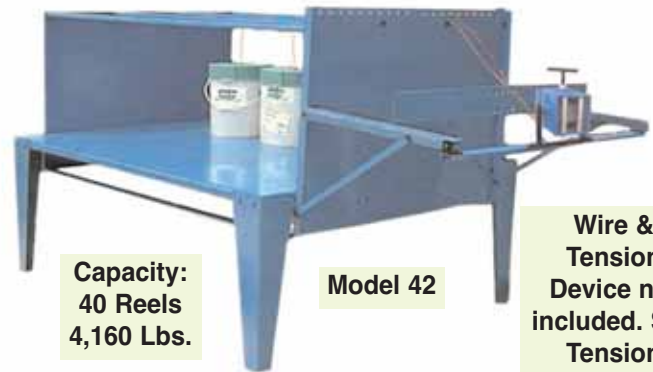

**Capacity:**  
40 Reels  
4,160 Lbs.

**Model 42**

**Wire & Tension Device not included. See Tension Device below.**

Model	Shipping Weight	Catalog Number
42	500 lbs.	CWDE42

**ACE Model 46 Tension Device** is designed particularly for handling group multiple round, square, rectangular, or flat wires used in group, loop, or transformer winding operations. Controlled pressure is applied to the wire as it passes between pressure plates. These plates will not tear or damage the insulation on the wires.



Model	Shipping Weight	Catalog Number
46	60 lbs.	CWDE46

**Model 3 Series Coil Winders** are automatic stop, constant torque, medium duty machines designed to wind small, medium and large coils. These machines utilize a Flux Vector Drive which provides soft, smooth starting and stopping. Controlled acceleration from zero to full speed prevents shock loads and helps reduce wire breakage. This machine represents the latest technology in coil winding and offers infinite speed and torque ranges. This machine is very versatile and is ideal for many types of winding.



Model	Type	RPM Speed	Lbs. Ft. Torque	RPM Speed	Lbs. Ft. Torque	H.P.	Voltage	Catalog Number
3-VAS	I	0 - 408	44	0 - 43	420	3	230/460/3/60*	CWDE3VAS1
3-VPAS	I	0 - 408	44	0 - 43	420	3	230/460/3/60*	CWDE3VPAS1
3-VAS	II	0 - 296	62	0 - 31	587	3	230/460/3/60*	CWDE3VAS2
3-VPAS	II	0 - 296	62	0 - 31	587	3	230/460/3/60*	CWDE3VPAS2
3-VAS	III	0 - 259	78	0 - 27	741	3	230/460/3/60*	CWDE3VAS3
3-VPAS	III	0 - 259	78	0 - 27	741	3	230/460/3/60*	CWDE3VPAS3
3-HVAS	I	0 - 710	43	0 - 75	408	5	230/460/3/60*	CWDE3HVAS1
3-HVPAS	I	0 - 710	43	0 - 75	408	5	230/460/3/60*	CWDE3HVPAS1
3-HVAS	II	0 - 512	60	0 - 54	570	5	230/460/3/60*	CWDE3HVAS2
3-HVPAS	II	0 - 512	60	0 - 54	570	5	230/460/3/60*	CWDE3HVPAS2
3-HVAS	III	0 - 431	71	0 - 45	675	5	230/460/3/60*	CWDE3HVAS3
3-HVPAS	III	0 - 431	71	0 - 45	675	5	230/460/3/60*	CWDE3HVPAS3

Shipping Weight  
475 lbs.

\* 50 Hz. available at additional cost.

**"P"** in Model No. designates 16 level programmable stop. Other units are single level programmable stop only.



**MARTINDALE** • 1375 Hird Ave • Cleveland, OH 44107  
 Phone (216) 521-8567 • Fax Local 521-9476 / USA & Canada (800) 344-9191  
 E-Mail: sales@martindaleco.com  
 Web Site: [www.martindaleco.com](http://www.martindaleco.com)

**Heavy Duty Coil Winding**

**Model 431 & 432 De-Reeling and Tension Stands** are air operated by means of regulated air pressure and gauge. Designed to handle spools and reels of round and shaped wire. Tension can be varied via an adjustable air pressure regulator which actuates a caliper brake gripping a 12" (standard) diameter disk. Supplied with either one or two shafts and one brake per shaft. Additional brakes per shaft are available.

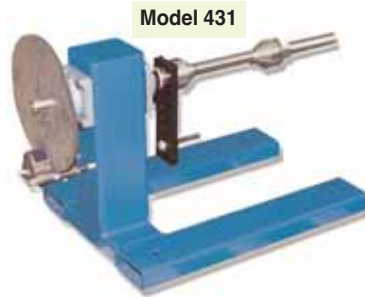

Model	Shipping Weight	Catalog Number
431	350 lbs.	CWDE431
432	500 lbs.	CWDE432

**Model HD** is a constant torque winding machine with an AC Flux Vector Drive. Engineered for those who require a versatile coil winder with extra high pulling power, and an infinitely variable speed range.



Model	Face Plate Load	Speed RPM	Lbs. Ft. Torque	H.P.	Voltage	Catalog Number
HD-03-1	5,300	0 - 39 / 77	363 / 184	3	460/230/60*	CWDEHD031
HD-03-2	5,300	0 - 53 / 105	267 / 135	3	460/230/60*	CWDEHD032
HD-03-3	5,300	0 - 97 / 192	146 / 74	3	460/230/60*	CWDEHD033
HD-05-1	5,300	0 - 28 / 55	844 / 430	5	460/230/60*	CWDEHD051
HD-05-2	5,300	0 - 39 / 77	606 / 307	5	460/230/60*	CWDEHD052
HD-05-3	5,300	0 - 53 / 105	446 / 225	5	460/230/60*	CWDEHD053
HD-05-4	5,300	0 - 97 / 192	244 / 123	5	460/230/60*	CWDEHD054
HD-10-1	8,000	0 - 28	1688	10	460/230/60*	CWDEHD101
HD-10-2	8,000	0 - 39	1212	10	460/230/60*	CWDEHD102
HD-10-3	8,000	0 - 53	891	10	460/230/60*	CWDEHD103
HD-10-4	8,000	0 - 73	648	10	460/230/60*	CWDEHD104

Shipping Weight  
1,300 lbs.

\* 50 Hz. available  
at additional cost.



## Single and Three Phase Winding Heads

**Model No. 15-L** is a Single Phase Winding Head and will wind practically any single phase motor, 3600 to 1800 r.p.m. Eleven sets of forms — adjustment needed for length only.

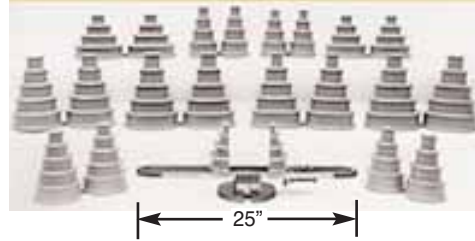

Model	Shipping Weight	Catalog Number
15-L	35 lbs.	CWDE15L

**Model No. 15-T** Three Phase Winding Head only requires one setting. Measure the length of the insulation in the slot. When the span is exactly the width of the form, this is all the measurement required.

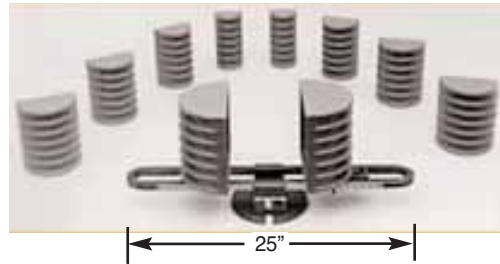

Model	Shipping Weight	Catalog Number
15-T	23 lbs.	CWDE15T

## Three Phase Group Winding Heads

**Four Group Winding Heads are available;** No's. 5, 10 and 11 are illustrated. Specifications for all four are given in the table below. No. 10 and No. 11 has one set of medium range jaws; No. 5 has a smaller set; No. 12 has the largest set. These group heads make three phase random mush coils in diamond, square, or rectangular shapes, from 1/4 h.p. to 125 h.p. capacity and can be bolted to any winding head face plate. The head is graduated to scale, making it easy to record specific job set-ups for repetition later. Winding is done at high speed. Six coils can be released and the next six set up in the machine in 10 seconds by means of a single action cam collapse mechanism.

**No. 5 Group Winding Head**

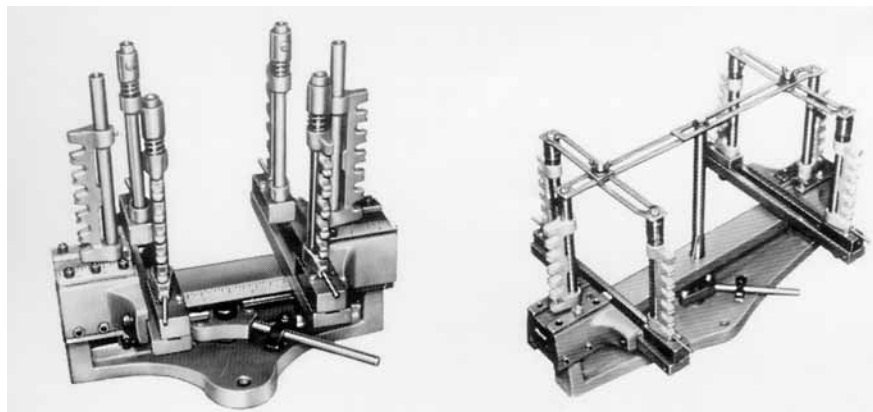

**No. 10 and 11 Group Winding Head with braces in position**

Model	Range of Coil Sizes			Wt. Lbs.		Catalog Number
	Length	Width	Slot Length	Net	Ship.	
No. 5	5" - 11-1/2"	2" - 6-1/2"	2-1/4" - 6"	29	46	CWDE5
No. 10	5-3/4" - 20"	3" - 10"	3-1/2" - 13"	50	80	CWDE10
No. 11	5-3/4" - 24"	3" - 14"	3-1/2" - 18"	55	90	CWDE11
No. 12	5-3/4" - 36"	3" - 24"	3-1/2" - 29"	150	200	CWDE12



**MARTINDALE** • 1375 Hird Ave • Cleveland, OH 44107  
 Phone (216) 521-8567 • Fax Local 521-9476 / USA & Canada (800) 344-9191  
 E-Mail: sales@martindaleco.com  
 Web Site: [www.martindaleco.com](http://www.martindaleco.com)

## Bench Type Coil Winder



This compact, reasonably priced, coil winder is designed for smaller shops where winding may not be done every day and also for larger shops as a secondary utility winder.

Used primarily with one of the winding heads shown below, this winder can produce field, mush, armature, solenoid, electromagnet, and other small coils. It is equipped with sealed bearings on all shafts and is engineered for smooth operation with constant torque and positive stopping for precise control over every job. The clutch and brake can be controlled either by hand or with the foot pedal with chain. There are three speed adjustments which can be made by simply changing the belts on the pulleys (Low — 108 rpm — 28 ft./lbs. torque) (Medium — 220 rpm — 15 ft./lbs. torque) (High — 440 rpm — 7 ft./lbs. torque). All three versions of this machine come equipped with a heavy duty counter.

See Coil Winding Heads below.

Model No.	Motor	Shipping Weight	Catalog Number
2057	1/3 H.P., 115 V., 60 Hz.	57 lbs.	CWDE2057
2069	1/3 H.P., 230 V., 60 Hz.	57 lbs.	CWDE2069
2067	1/3 H.P., 230 / 460 V., 60 Hz.	57 lbs.	CWDE2067

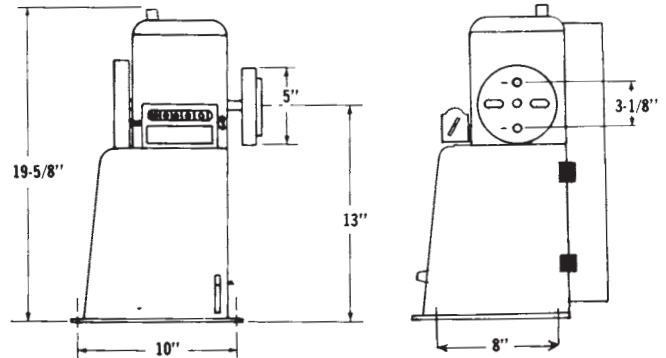

### Model 2101



## Coil Winding Heads

For above Winders

**Model 2101** for winding relatively small armature, solenoid, and field coils. Comes with 6 adjustable coils spools.

**Models 2103 & 2106** for winding 3 Phase Coils from fractional HP to 300 HP. Four permanently mounted cranks adjust winding arms simultaneously. Built-in easy to read scale assures accuracy and ease of set-up.

### Models 2103 & 2106

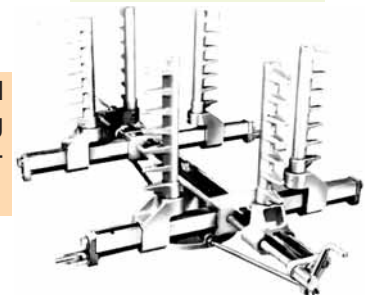

### Model 2104

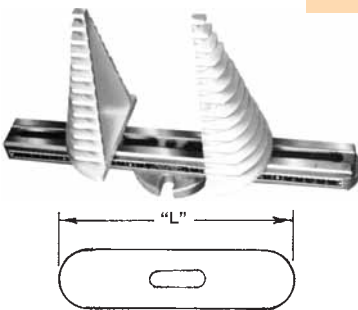

**Model 2104** Single Phase Head is fully adjustable for single phase coils. Features 13 slots and easy to read scale for fast set-up.

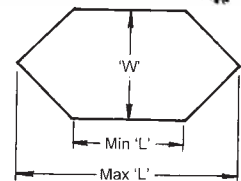

Model No.	Range of Coil Sizes		Weight - lbs. Net/Shipping	Catalog Number
	Length	Width		
2101	6" to 16"	3" to 13"	30 33	CWDE2101
2103	5" to 19"	2" to 11"	25 27	CWDE2103
2106	8" to 28"	4" to 16"	27 36	CWDE2106
2104	3" to 13"	.724" to 4.322"	12 16	CWDE2104

